

## **Basis of Design**

This section applies to the design of parking lots and other parking areas.

### **Design Criteria**

- Provide a finish surface for all asphalt concrete paving that is dense, uniform in texture, smooth and free of hollows, depressions, roller marks, and surface cracks.
- Construct all areas of 3 inches of asphalt concrete paving Class B over 4 inches crushed surfacing top course.

## **Design Evaluation**

**The following information is required to evaluate the design:**

- Design Development Phase: Show area of parking lot. Show cross section of pavement section. Provide preliminary specifications for all paving materials.
- Construction Document Phase: Details, elevations at all edges and breaks, and specifications.

## **Construction Submittals**

- Asphalt Design Mix
- Crushed Surfacing Top Course gradation

## **Related Sections**

- None

## **Product, Materials and Equipment**

- The grade of asphalt concrete paving shall be AR-2000 or AR 4000 as specified.
- Manufacture mineral aggregates for Asphalt Concrete from materials meeting the following test requirements: Los Angeles Wear (ASTM Designation C 131) 50 Rev. 30% Max.
- Crushed Surfacing Top Course shall meet the gradation as shown in the latest WSDOT Standard Specifications.

## **Installation, Fabrication and Construction**

Comply with the following standards in the installation and placement of Asphalt Concrete Paving:

### **Asphalt Concrete Hauling**

- The Asphalt Concrete mixture shall leave the Mixing Plant at a temperature between 260° F and 350° F and be not less than 250° F when deposited on the roadway.
- Transport the mixture in suitable dump trucks of sufficient size and shape to easily accommodate the load.

- When required by the University of Washington, cover each load with a suitable tarpaulin while in transit to prevent spillage and/ or to prevent unnecessary heat loss.

### **Preparation of Existing Surfaces**

- Compact Crushed Surfacing Top Course to 95% of optimum density (Modified Proctor)
- Remove all fatty asphalt patches, grease drippings and other objectionable matter from existing asphalt surfaces.
- Sweep the existing pavement to remove dust and other foreign matter.
- Uniformly apply a tack coat of emulsified asphalt at the rate of .02 to .05 gallons per square yard of retained asphalt to all existing surfaces on which any course of asphalt concrete is to be placed.

### **Preparation of Asphalt Patches**

- Where existing asphalt concrete pavement must be removed and patched, remove all deteriorated asphalt concrete and soft sub-base by making vertical cuts in the asphalt at least 6 inches beyond the deteriorated asphalt concrete.
- Replace the Crushed Surfacing Top Course to 95% density of its proctor (modified). Apply asphalt concrete a minimum of 3 inches deep.

### **Miscellaneous Details of Construction**

- Do not proceed with construction of one course or lift upon another until the underlying course is completely cooled and set.
- Do not deposit asphalt concrete mixture if the rolling cannot be completed before dark.
- Do not place asphalt concrete in standing water.
- Where the asphalt concrete is to be placed against concrete or stone curb or gutter, or against a cold pavement joint or any metal surface, apply a thick paint of cutback asphalt in advance of the placing.
- The finished surface, when tested with a 10-foot straight edge, shall reveal no deviation in excess of  $\frac{1}{4}$  inch.
- Take core samples, 4 inches in diameter, to verify total asphalt thickness. The Contractor shall patch all the test holes to the satisfaction of the University of Washington.
- See Parking Area Right Angle Parking drawing.
- See Typ. Parking Area Spacing drawing.
- See Precast Parking Block drawing.

END OF DESIGN GUIDE SECTION

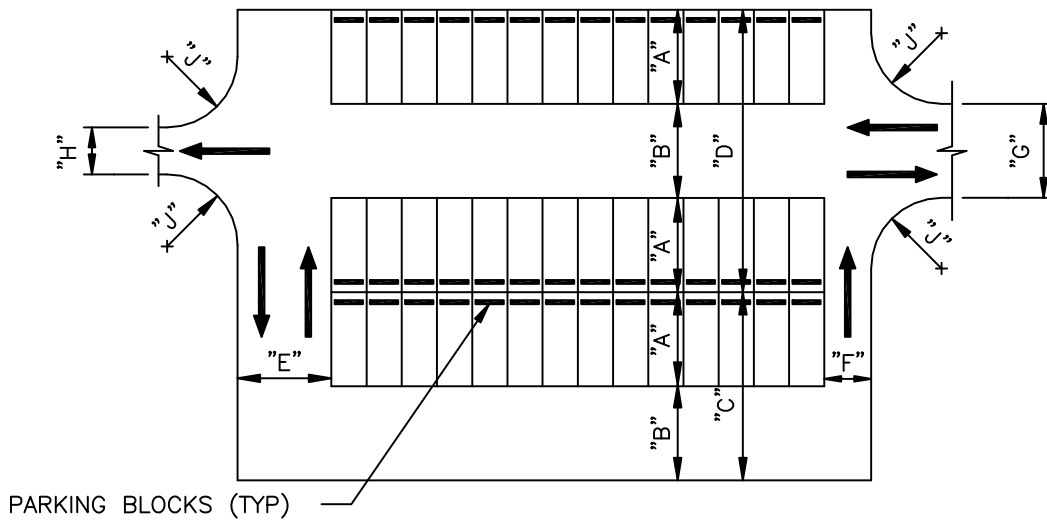

PARKING PLAN

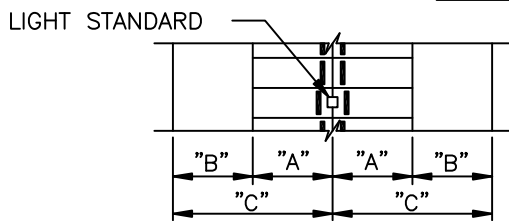

DOUBLE ROW

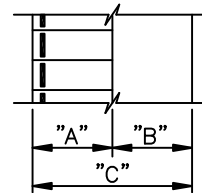

SINGLE ROW

STALL AND AISE DIMENSIONS NOTE 1										
ANGLE	DIRECTION	"A"	"B"	"C"	"D"	"E"	"F"	"G"	"H"	"J"
90°	BACK IN	20'	20'	40'	60'	20'	10'	20'	10'	15'
90°	DRIVE IN	20'	20'	40'	60'	20'	10'	20'	10'	15'

NOTES:

1. DIMENSIONS SHOWN ARE FOR AVERAGE CAR STALLS. SEE SD-C-66 FOR DIMENSIONS OF SMALL CAR STALLS.
2. DIMENSIONS "E" & "G" ARE FOR TWO-WAY TRAFFIC. THESE INCLUDE ALLOWANCE FOR EXTRUDED CURBING ALONG THE PERIMETER.
3. DIMENSIONS "F" & "H" ARE FOR ONE-WAY TRAFFIC AND INCLUDE ALLOWANCE FOR EXTRUDED CURBING ALONG THE PERIMETER.
4. FOR MORE INFORMATION AND NOTES OF RIGHT ANGLE PARKING SEE TYPICAL PARKING AREA SPACING DWG.

SD-C-65

**Parking Area Right Angle Parking**

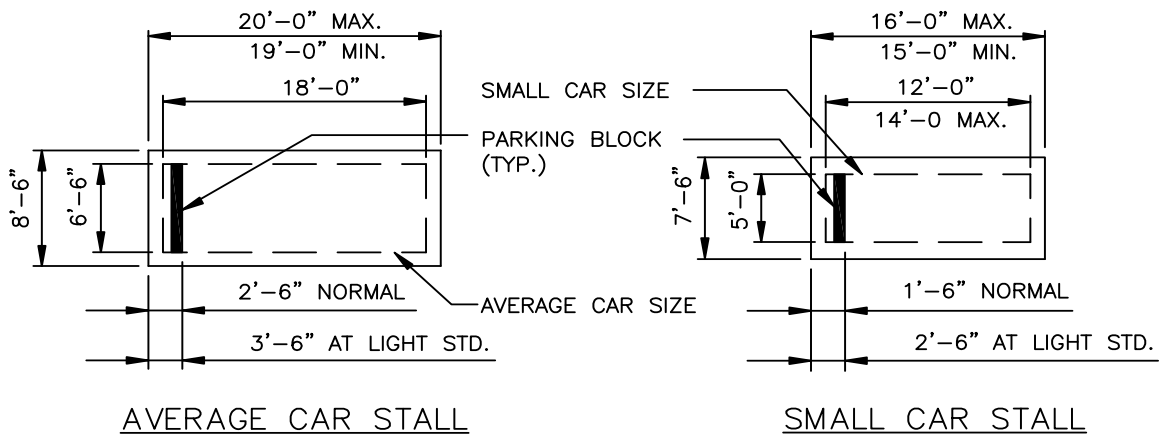
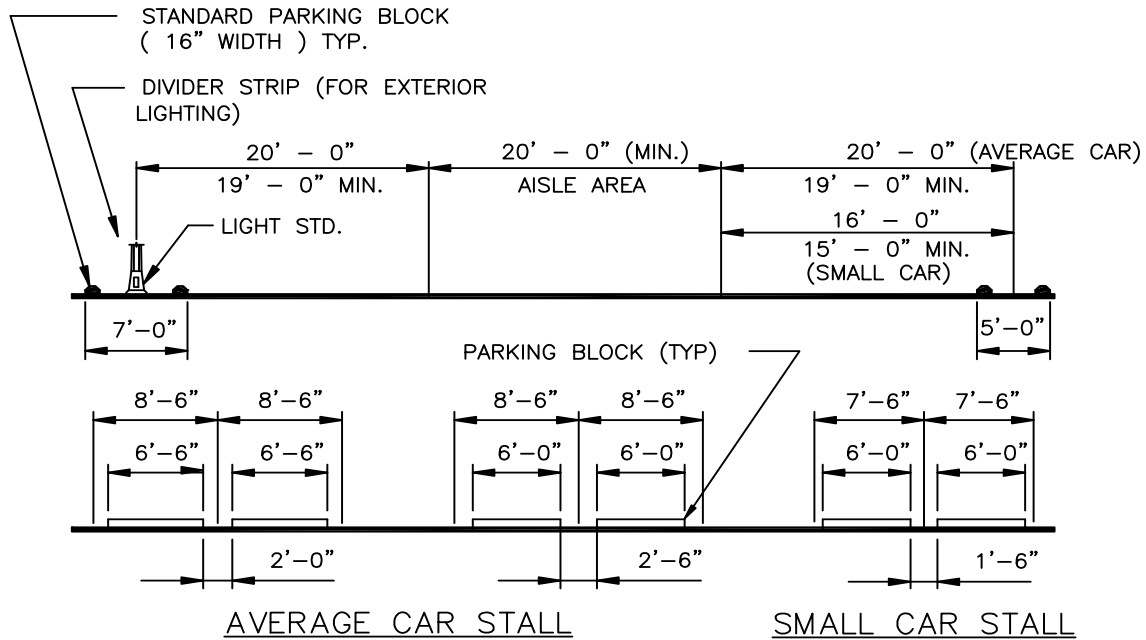

NOTES:

1. BEFORE FINALIZING PLANS FOR PARKING AREAS, CONSULT THE UNIVERSITY LANDSCAPE ARCHITECT FOR PLANTING REQUIREMENTS.
2. THE FINAL DESIGN FOR ALL PARKING AREAS IS SUBJECT TO APPROVAL BY THE UNIVERSITY LANDSCAPE ARCHITECT.
3. FOR MORE INFORMATION AND NOTES SEE RIGHT ANGLE PARKING DRAWING.

SD-C-66

Typical Parking Area Spacing

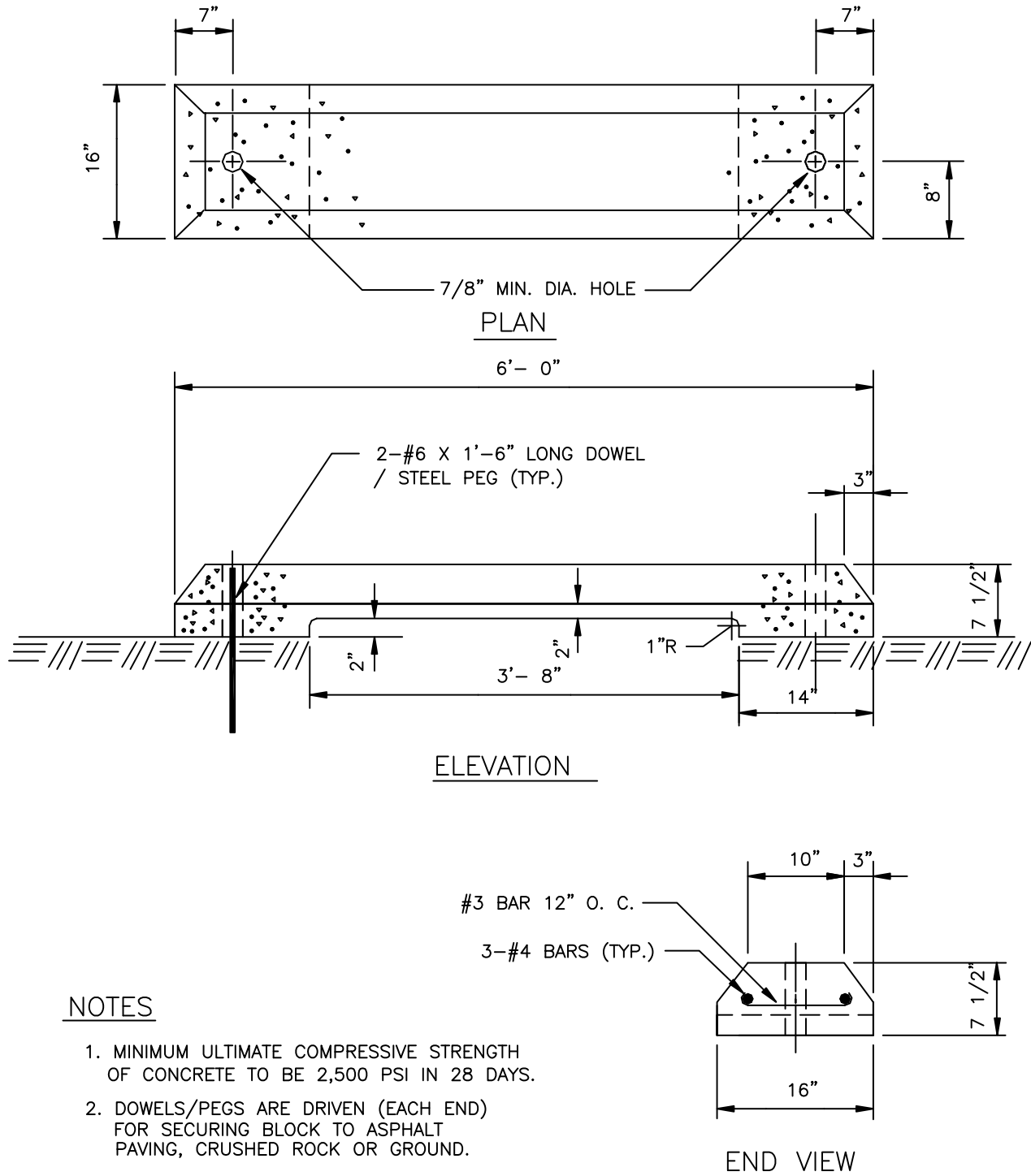

SD-C-54

**Precast Parking Block**